

## **(Original) Use and maintenance manual**

**Type: Splice Presses**  
**Model: EP-120**



### **IMPORTANT:**

Read this user manual and follow the instructions and warnings before operating this device.

Any modification or transformation performed on this machine may cause loss of the manufacturer's guarantee and liability.

This manual must always remain near to the machine and visible to all the operating and maintenance staff, for any future consultation, forming part of the equipment.

**Index:**

	<b>Page</b>
- <b>CE declaration of conformity:</b> .....	<b>3</b>
- <b>Description of the equipment:</b> .....	<b>4</b>
- <b>Workshop installation:</b> .....	<b>4</b>
- <b>Connection of the Control Box:</b> .....	<b>6</b>
- <b>Equipment identification:</b> .....	<b>8</b>
- <b>Technical characteristics:</b> .....	<b>9</b>
- <b>Instructions for use:</b> .....	<b>10</b>
<i>Preparing the joint:</i> .....	<i>10</i>
<i>Inflation:</i> .....	<i>13</i>
<i>Connection:</i> .....	<i>16</i>
<i>Programming:</i> .....	<i>17</i>
<i>Connecting the cooling system:</i> .....	<i>19</i>
<b>Cooling by water</b> .....	<b>19</b>
<b>Cooling by air</b> .....	<b>21</b>
- <b>Electrical drawings:</b> .....	<b>24</b>
<i>3x400V</i> .....	<i>25</i>
<i>3x230V</i> .....	<i>26</i>
- <b>Spare parts:</b> .....	<b>27</b>

- **CE declaration of conformity:**

WE DECLARE, under our responsibility, that the machine:

- Type: Splice press
- Brand: ERM Engineering
- Model: EP-120
- Serial No.: 12535
- Manufacturer date: 2024

Inspired by the directives of the Official Journal of the European Communities:

**2006/42/CE Machinery Directive**

**2014/35/UE Low Voltage Directive**

**2014/30/UE Electromagnetic Compatibility Directive**

Complies with the design and construction specifications of the European Standards on General Machine Safety:

**EN 349 - EN 614-1 - EN 614-2 - EN 12100 - EN 11161-1 - EN 1005-1 - EN 1005-2 - EN 1005-3 - EN 1005-4 - EN 13849-1 - EN 13849-2 - EN 894-3 - EN 61310-1 - EN 13732-1 - EN 13850 - EN 13857 - EN 14120 - EN 60204-1**

General Manager: Eduardo Ramos Martínez



ermengineering  
belting fabrication equipment

Arenys de Munt (Barcelona)-SPAIN

Date: 2024/07

- **Description of the equipment:**

Heating press for fusion welding of conveyor belts, comprised of two aluminium plates with cartridge electric elements, controlled by an external temperature board.

- Pressure by pneumatic cushions to guarantee uniform pressing.
- Intermediate support tray to prepare and hold the joint while hot.
- Interior cooling circuit by water, and by air in some models, too.

- **Workshop installation:**

These presses may be used both for in-situ assembly, as well as in fabrication workshops, for which it is recommended to adapt the press to a metallic supporting structure, with pneumatic or counterweighted activation, to open the top plate and adapt the water cooling circuits correctly.



Fig-1

Fig-2

Place the control board on the rack at eye level, safely to avoid it breaking or falling.

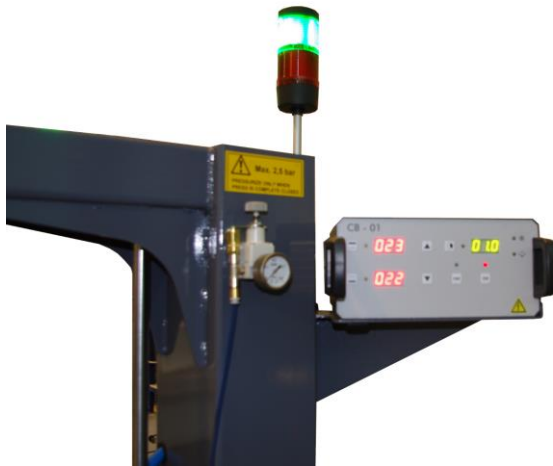

Level the support with the regulation screws located inside the three feet.

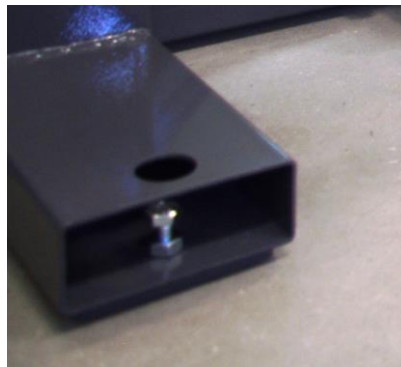

Install the cooling and purge control unit CU-01 on the rear of the support.



Connect the water intake and electric power on the closed side of the support to facilitate extraction of the belt once it has been joined.



**NOTE:** In the case of several presses being connected to the same drainage line, installation of a one-way valve at each press is recommended, thus avoiding water entering the other presses during the purge process.

- **Connection of the Control Box:**

Before connection to the mains, make sure the rear magneto-thermal lever is down.

- Before connecting the power cable of equipment **H** to the mains, check the voltage recorded on the characteristics plate of the unit, located on the rear label of the board.
- Connect the power cables of press **C** and **D** to the respective top and bottom plates.

**NOTE:** If we turn on the equipment without the power cables connected to the press, the temperature controls will show a reading error.

Activate the rear lever of the safety magneto-thermal device and its differential switch **B**.

When the equipment is switched on, it will show the values programmed when last used, by default.

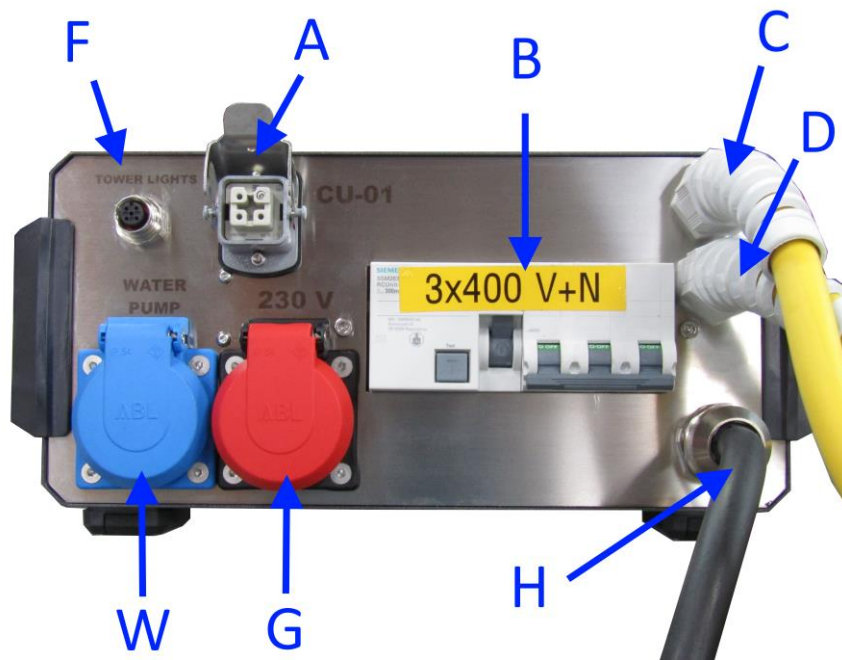

- A- Connector of control unit CU-01 Cooling and purge
- B- Protection thermal differential
- C- Top element connection cable
- D- Bottom element connection cable
- F- Auxiliary connector for light in frames
- G- Socket with permanent voltage 230v
- H- Power cable
- W- Socket for water pump (automated function)

- **Equipment identification:**

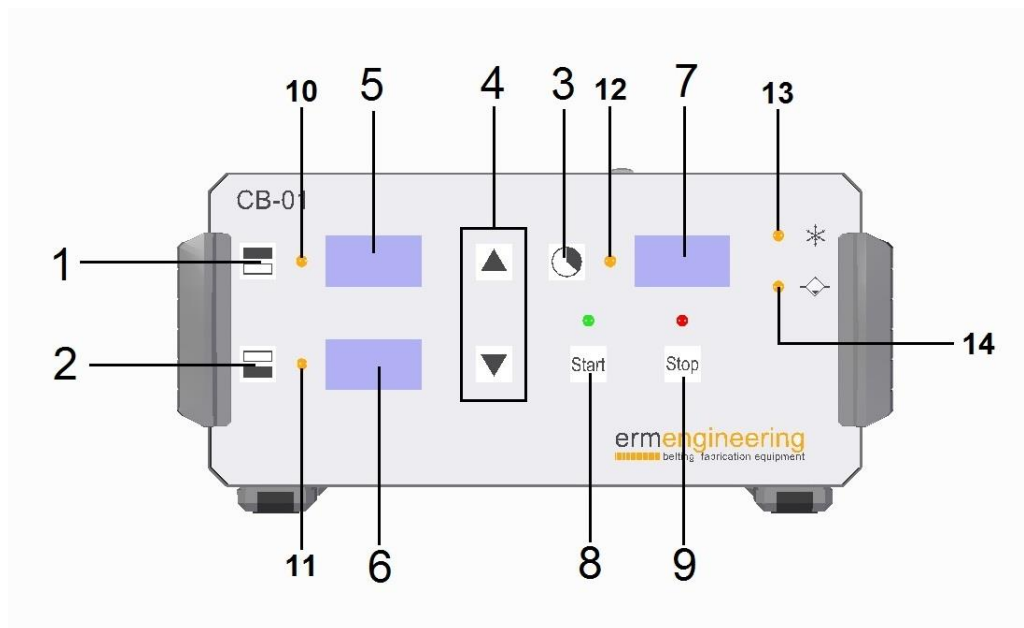

- A- Temperature selection button, top element C°
- B- Temperature selection button, bottom element C°
- C- Welding time selection button
- D- Modify value buttons (increase or decrease)
- E- Top element temperature
- F- Bottom element temperature
- G- Welding time in minutes
- H- Start welding cycle button
- I- Button to halt or stop the process
- J- Power induction marker of the top element
- K- Power induction marker of the top element
- L- Timer start marker
- M- Element cooling process marker
- N- Water circuit purge process marker

**NOTE: The 5 and 6 temperature display always show the present temperature of the heating elements. To visualise the value programmed, just press either of the two buttons of each element, 1 and 2.**

**The display of timer 7 always shows the value programmed in minutes, except when commencing welding time, that will be displayed in countdown mode.**

- **Technical characteristics:**

	EP-120
- Heating area	160x1250mm.
- Dimensions (LxWxH)	1570x360x335mm.
- Upper part weight	33.6 Kg.
- Lower part weight	33.8 Kg.
- Steel plate and clamps weight	18.4 Kg.
- Total weight	85.8 Kg.
- Power consumption	6000 W.
- Electric power supply	3x230//3x400 V.+N
- Frequency	50-60Hz
- Maximum pressure	2.5 bar
- Belt thickness max.	12mm
- Minimum length belt with steel plate	880mm.
- Minimum length belt without steel plate	680mm
- Max. temperature	200°C
- Cooling media	Water and air
- Mean heating time at 175°	9min
- Water cooling time from 175° to 60°	2.1 min.
- Air cooling time from 175° to 80	8 min.
- Current	8.1amp - 3x400 V

- **Instructions for use:**

Open the press by releasing and extracting the two closing bolts located at both ends of the top plate.

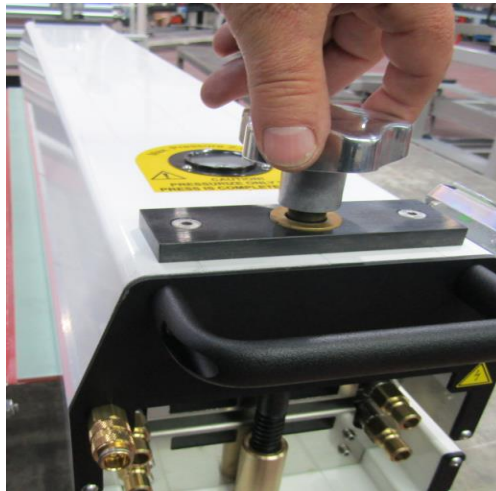

**WARNING:**

**Before opening the press, check that the inflation pressure of the manometer is 0 bar.**

**Preparing the joint:**

Place the first end of the belt on the lower silicone, well centred on the support tray and making sure the joint is within the welding zone of the bottom plate.

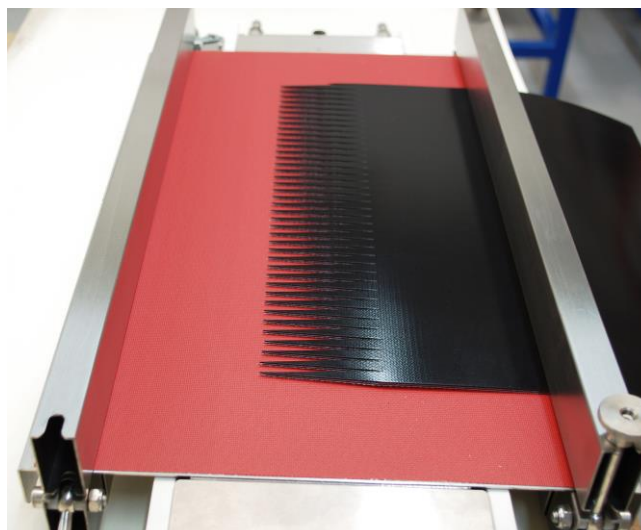

Then place two sufficiently large scraps and the same material offered up to weld, at both ends and properly tangential to the belt, and fix them using the same holding bar. (Fig-3)

It is also possible to use metal callipers of the same thickness as the belt and, when necessary, use scraps of the same belt after the callipers to fill out the welding zone.

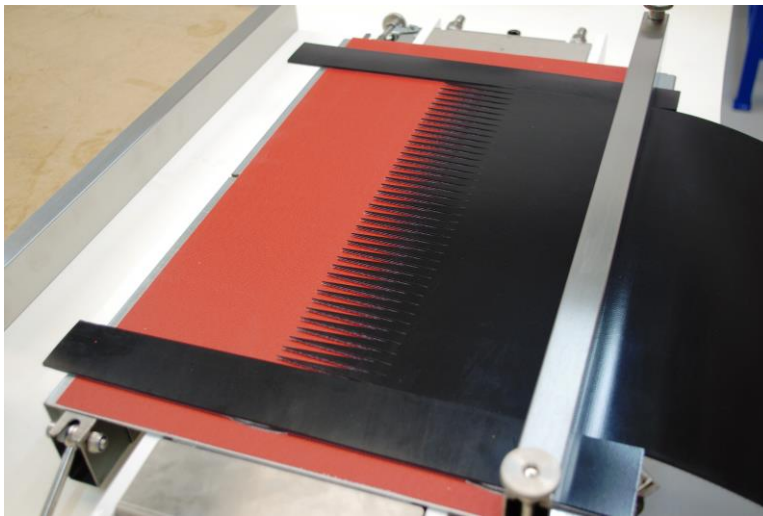
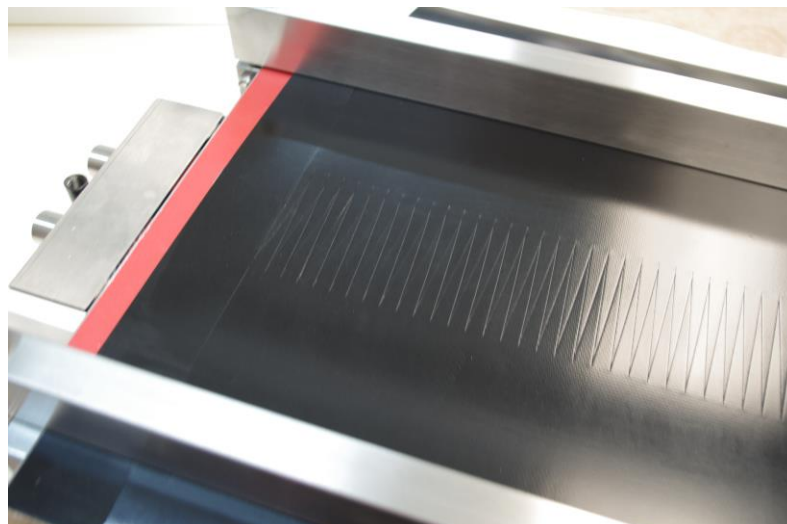

Fig-3

**NOTE: It is always recommendable to fill out the material, at least to 70% of the pressing surface, to avoid deformation in the plates or thickness differences in the welding.**

Afterward, insert the second end of the belt, leaving the whole surface to be joined fully in contact with the first end already fixed, and hold it with the other holding bar.



---

Once the joint placement operation has been completed, we cover the whole welding surface with silicone or adequate silicone paper recommended by the belt manufacturer.

So, on completing the welding, we guarantee that the joint zone has the same texture and finish as the rest of the belt.



Before closing the press, we place the metal or fibreglass plate, according to the material to be welded, to avoid marks caused by the radical change of temperature and pressure outside the welding zone.

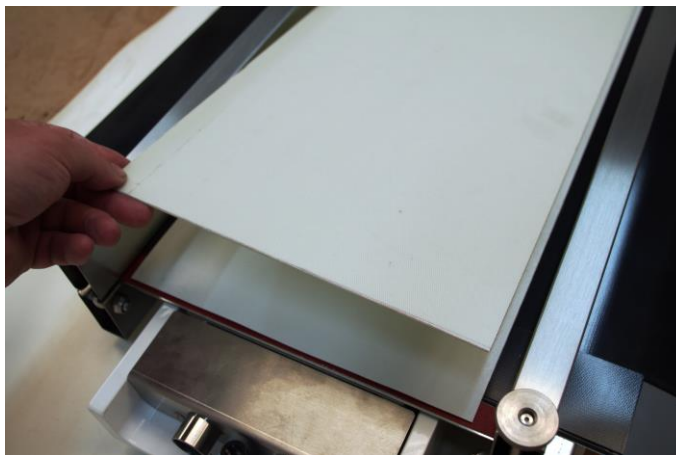

We close the press, centring the upper plate well against the lower one and making sure that the water and electrical connection are at the same end of the press.

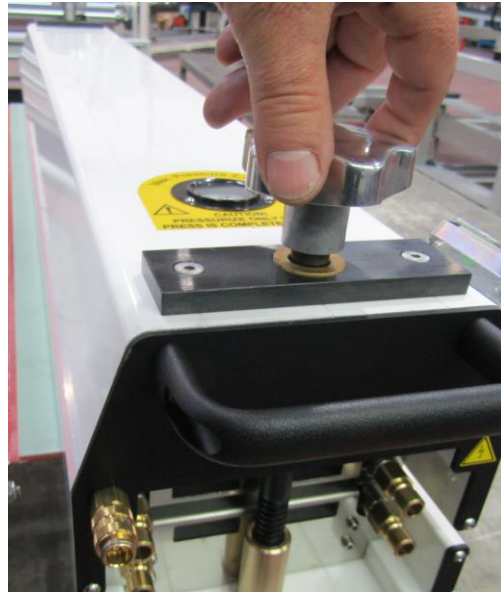

Once the upper plate has been put in place, we close the press using the closing controls, softly pressing with just two fingers, and in a balanced way on both sides.

**⚠ IMPORTANT:** To obtain homogeneous pressure throughout the surface, it is always recommended not to press the closing controls too much, so the pneumatic cushion will thus work in a more balanced way.  
**The closing screws to close the press must be tighten to the nut minimum 4 turns**

Now we can proceed to inflate.

### **Inflation:**

**⚠ WARNING:**  
**Always make sure the press is correctly closed before inflating.**  
**There is a risk of explosion of the top plate.**

We connect the power socket to on the compressor to the rear red connector on the board, or to another standard 230V. socket:



We then connect the inflation tube to the intake point on the press, simply by pushing it together

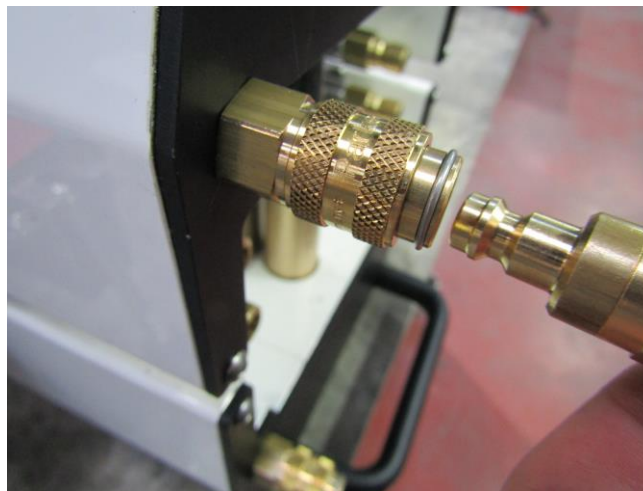

**NOTE:** If the press has a top and bottom cushion, we shall always connect the two sockets. Otherwise, the weld will not be acceptable. If the press only has one top cushion, we will only connect one tube.

We start up the compressor with the switch at position I.



We will control visually the inflation pressure by the manometer of the press, and we will stop the compressor with switch in position "O" once we have achieved the pressure wanted. In case more pressure is needed we can add more with the pressure regulator of the compressor.



**WARNING**

**Never exceed the maximum inflating pressure of the press 2.5 Bar**



Once the inflating pressure is finished, we can disconnect the intake air tubes of the press to avoid loss of pressure during welding.



Once the required pressure has been reached, we shall stop the compressor with 0 STOP and disconnect the air tube of the press, moving the ring of the coupling piece inward.

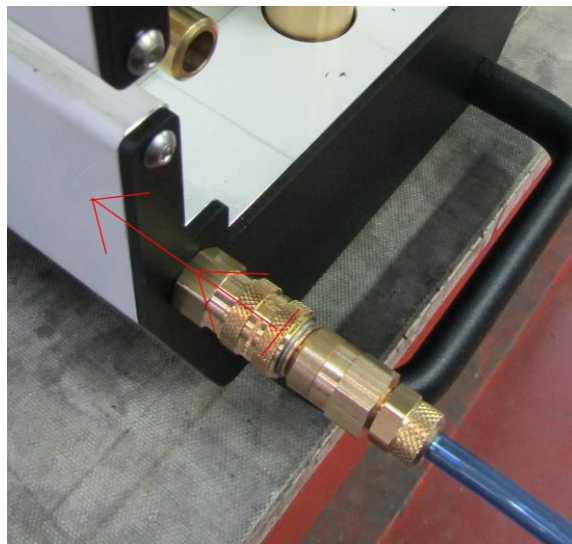

**NOTE:** If the press has two cushions, we must disconnect both the top and bottom tubes at the same time to prevent air leakage from the cushions.  
It is always recommended to disconnect the inflation tubes during the welding process to avoid pressure leaks through the valves of compressor.

### Connection:

We may now connect the control box.

For it, is recommended to check the voltage on the manufacture plate before connecting it to the grid.



We shall connect the power cables of the press from the control board CB-01 so they coincide with the reference colours.



Once the power cables are connected, we raise the lever on the main switch of the board located at the bottom.

### Programming:

Now of starting up the board, the actual temperatures of both plates are displayed, and the welding time of the last programming.



To see the temperatures assigned, press the relevant button for each plate.



To program these values, we must hold the button for 3 seconds and change the value using the central arrows to increase or decrease.



The board shall memorise these values, showing the present ones again.

**NOTE: The minimum and maximum temperatures that may be programmed are 30 to 200 °C.**

We shall perform the same operation to program the welding time, ALWAYS IN MINUTES. The values shown are complete minutes without decimals.



That welding time shall always show the programmed value, except for starting the count, that shall show the count-down until ending.

Once the two temperatures and time values are programmed, we press START.



**NOTE:** To halt the process or to make any change after beginning with START, we must press STOP and the cycle will stop.

### Connecting the cooling system:

#### Cooling by water

This connection of the cooling circuit hoses must be performed before the press reaches the welding temperatures; otherwise, this may lengthen the welding time.

To that end, we shall connect the two hoses from the water pump in each of the top and bottom plates, just as shown in the image.

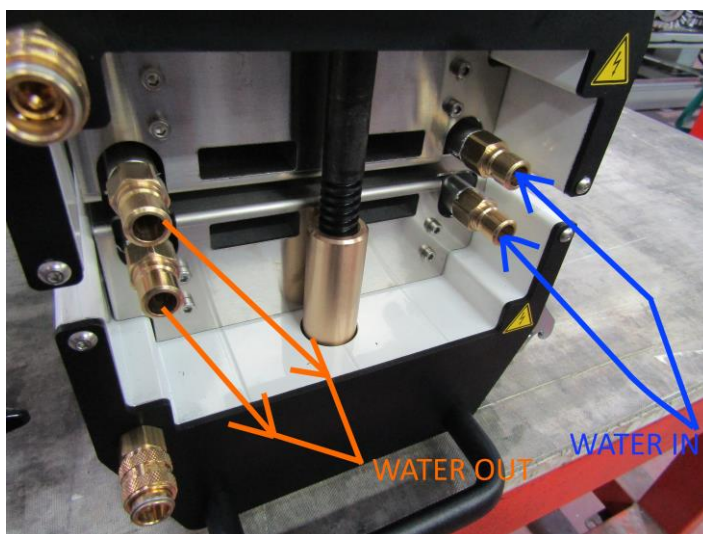

Afterward, we shall connect the two drainage hoses the other two top and bottom conducts.

When the welding time ends, the relevant orange LED to start that operation shall turn on.

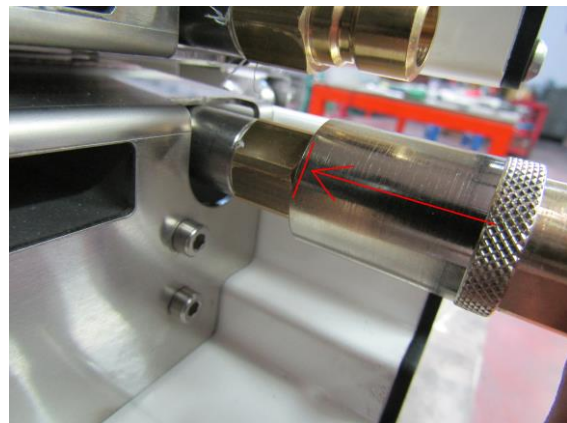

To connect the fast connector, we will move the ring backwards and we will put the racor inside pressing it completely in, in this moment we must move the ring towards the inside to fix closure.

**WARNING:**

**Make sure that the four hoses of the cooling circuit are completely connected to their proper connectors. Pull them to assure connection.**

**If they are not, water steam may go out.**

The cooling unit must be connected to the blue socket, which will automatically supply the electric power once the welding process is finished and will stop the cooling operation automatically once the process has finished with the press already cold:



**NOTE:** We shall not submerge or turn on the water pump until the welding time ends.



**IMPORTANT:**

After the welding operation, it is essential to purge the water inside the heating plates to avoid temperature differences in next operations.

If we have the control cool unit CU-01 in models FEP with support, the cooling and purge operations are controlled and done automatically by the electro valves of this unit, that must be connected to the rear power supply of the control box and the signal to the connector as shown on the picture.



### Cooling by air

Connect the AB-EP (air blower device) tubes to the back holes of the press as showed in the next picture

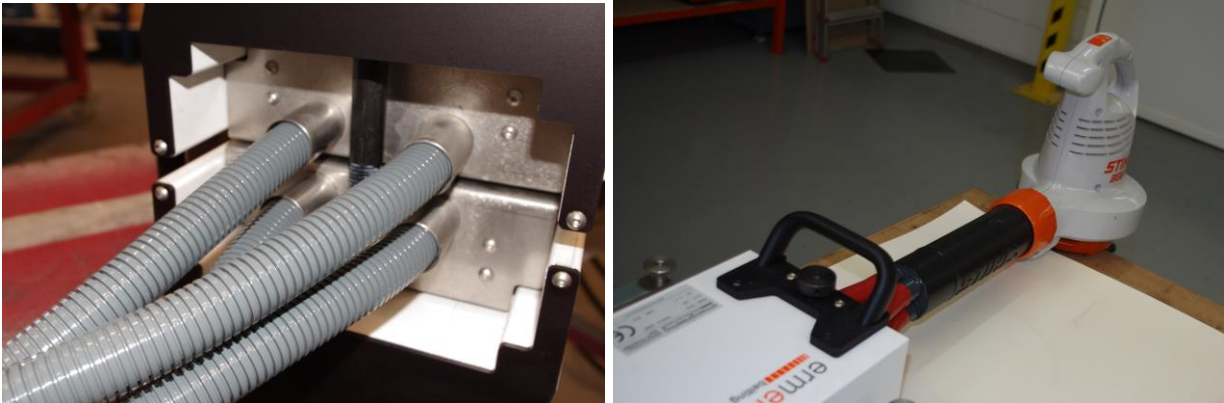

The air blower unit must be connected to the blue socket, which will automatically supply the electric power once the welding process is finished and will stop the cooling operation automatically once the process has finished with the press already cold:



We then connect the water pump, or the air blowing unit to cool the equipment, until reaching the temperature of 50 °C when we may stop the cooling.

**NOTE: This temperature 50°C can be modified if desired with secret menu.**

When the STOP led shows on the board, it means the operation has ended.



Once the welding is finished, we will depressurize the press inserting the same air connector. Without putting it all in causing air loss of the circuit, this must be done on both plates of the press.

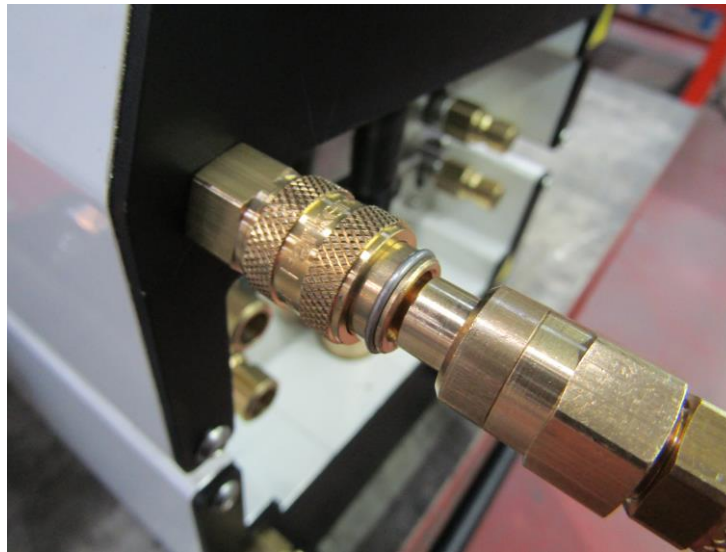

We can then proceed to open it.

**⚠ IMPORTANT:**  
**Only after having depressurized completely the cushions we can forward to open the press.**

- **Electrical drawings:**

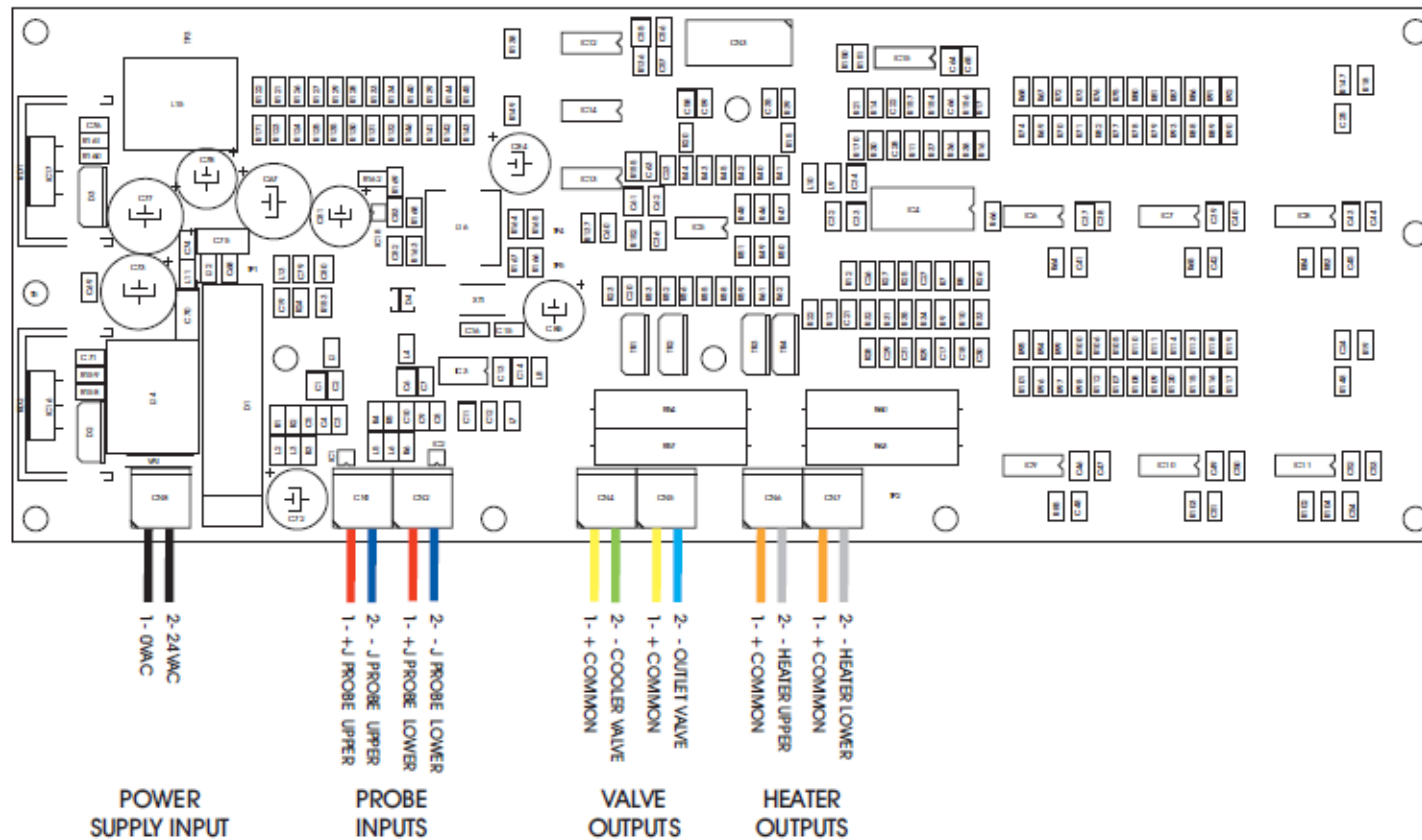

### 3x400V.

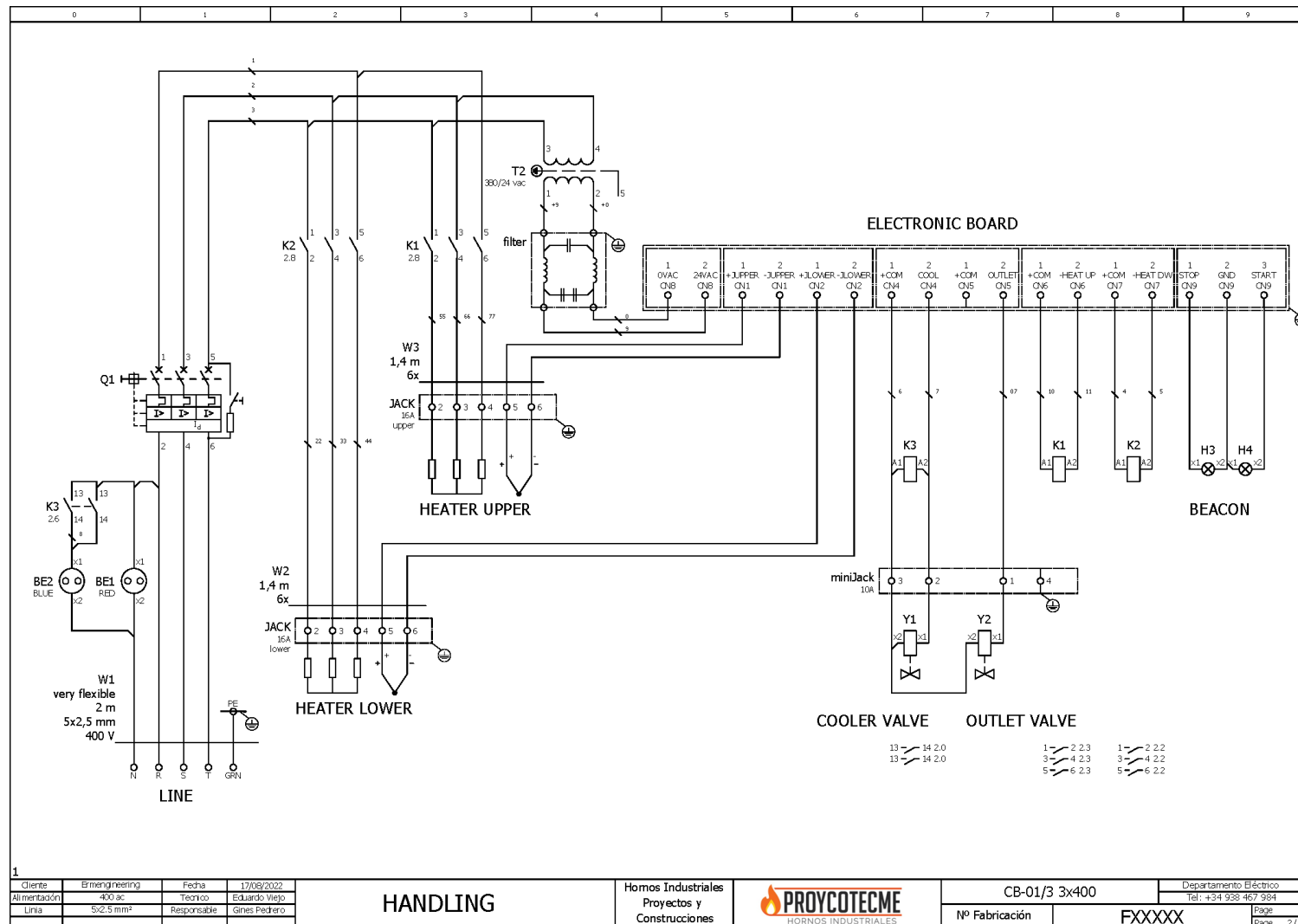

**3x230V.**

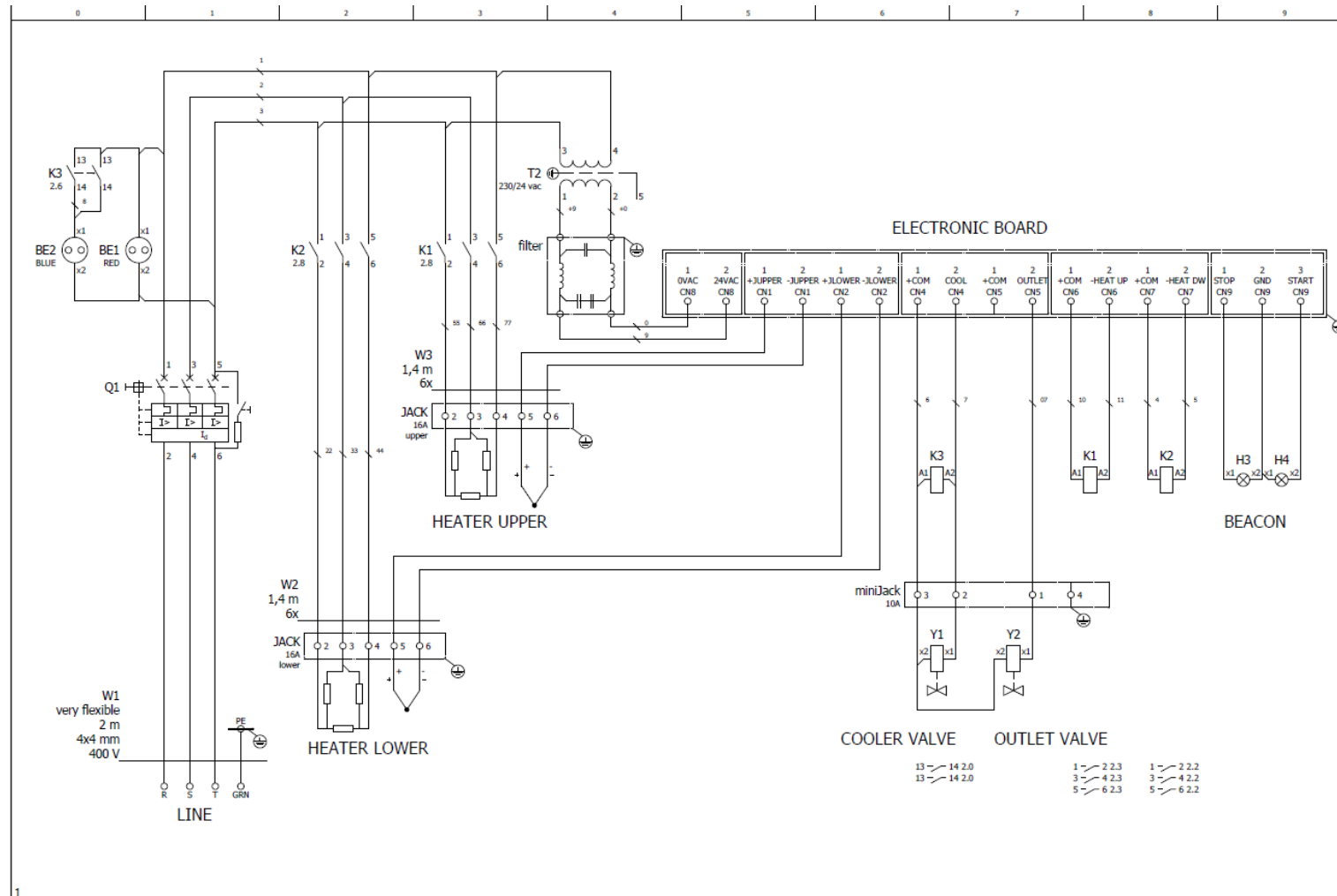

1	Emengineering	Fecha	17/08/2022
Alimentación	400 ac	Tecnico	Eduardo Viejo
Linea	5x2.5 mm²	Responsable	Gines Pedrero

**HANDLING**

Hornos Industriales  
Proyectos y  
Construcciones



CB-01/2 3x230		Departamento Eléctrico
		Tel: +34 938 467 984
Nº Fabricación	FXXXXX	Page 2 / 2

- **Spare parts:**

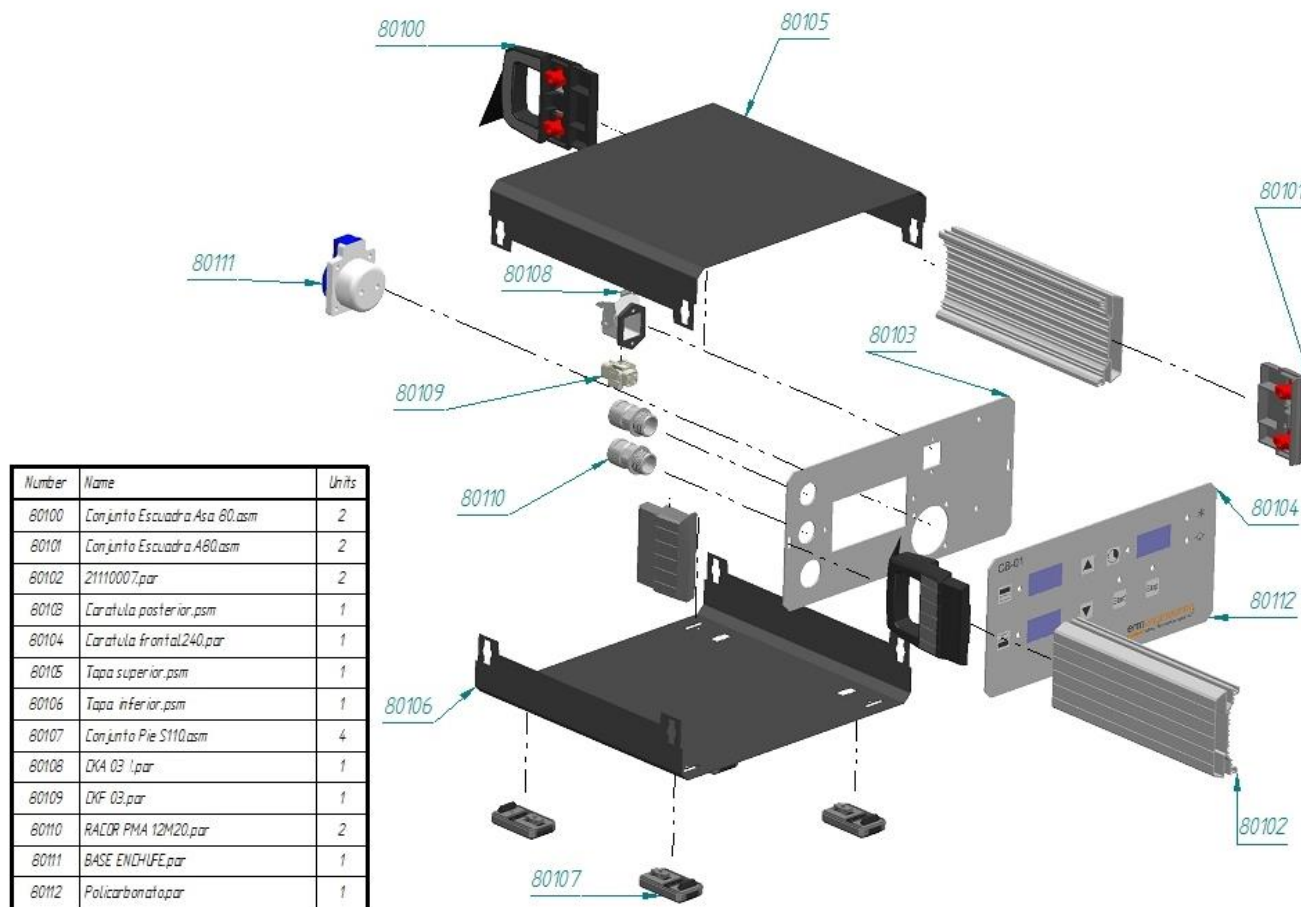

Number	Name	Units
80150	Pieza8.par	1
80151	OMEGA ABB.par	1
80152	Rele 3 fases.par	2
80153	Trafo.par	1
80154	Base contactores.psm	1
80155	Rele 1 fases.par	2
80156	MAG_ABB.asm	1
80157	DF_ABB.asm	1

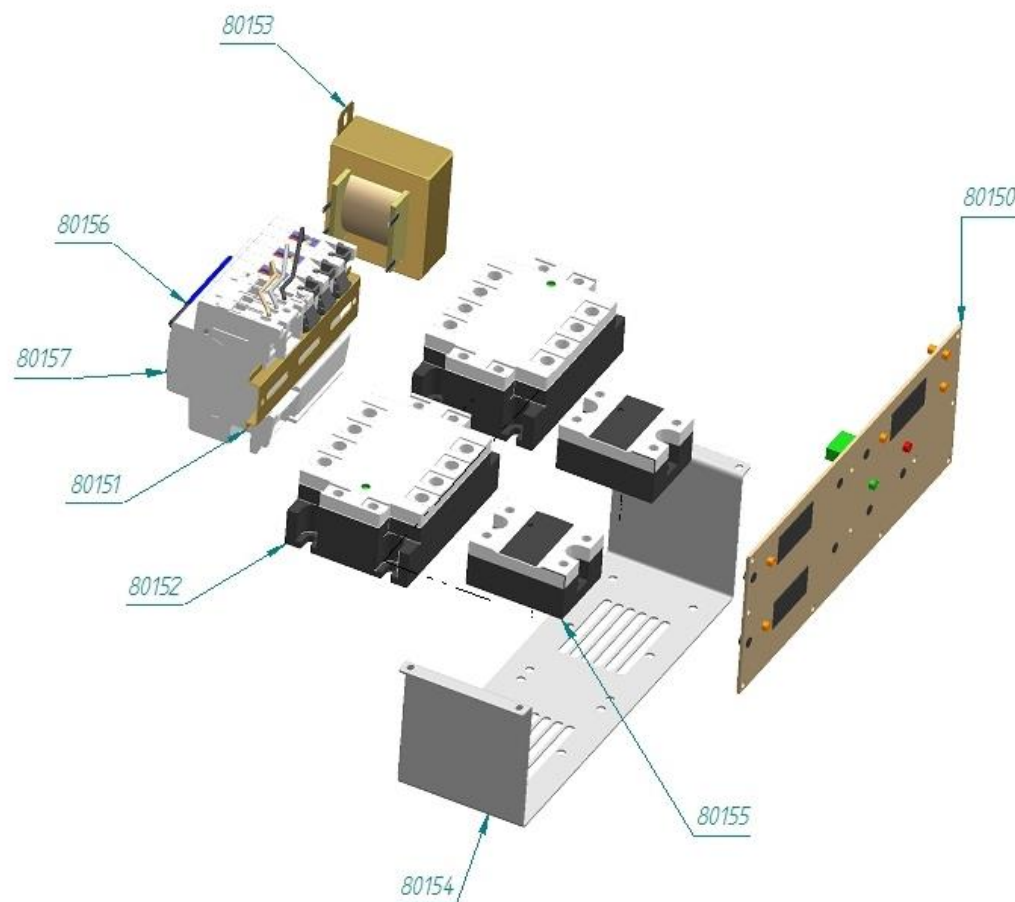

Number	Part name	Units
E12002	Aslante 25x1250.par	1
E2105	Bicono 0105_08_13.par	2
E2106	Bypas agua 45.par	1
E2108	Escuadra muelles.psm	2
E2116	KK4P_02FH1.par	2
E12004	Perfil plato 1250.par	1
E12000	Resistencia 1200.par	3
E2117	Sonda J.par	1
E2115	TUBO SALIDA AGUA.par	2

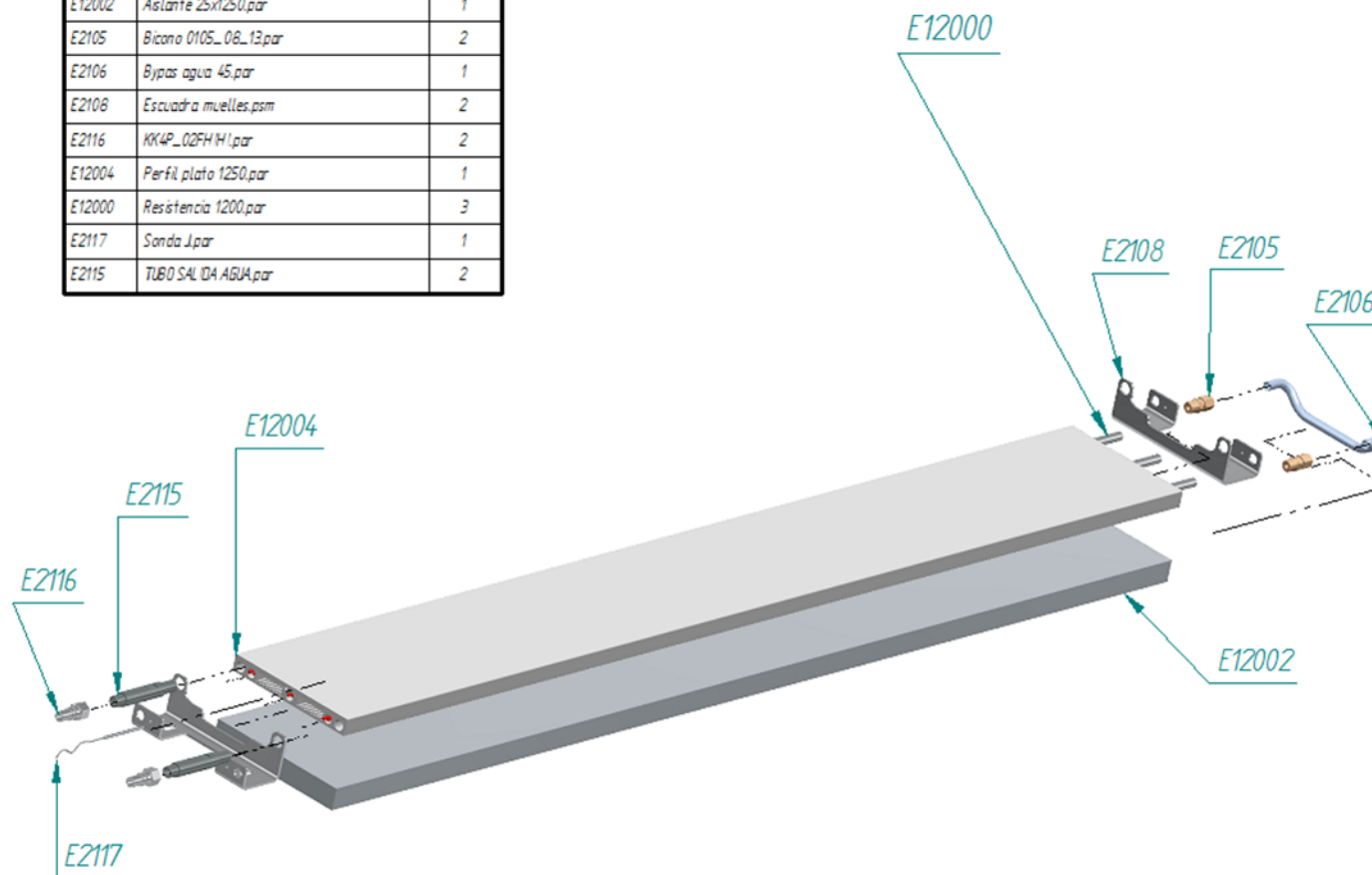



Número de documento	Part Name	Units
E12102	Chasis inferior 120-2013	1
E2102	DH/06 L	1
E2103	DNEM 06 T	1
E2101	565-1	2
E3034	Tapeta chasis cort-2	1
E3033	Tapeta chasis cort-1	1
E1008	KK2S-0&E.	1
E3016	Tapeta salida aire	1
E3008	Tapeta entrada aire	1
E2111	Placa cierre inf-1500	2
E1131	Tuerca cierre 2013-2	2
E2149	Screw_DIN_7991_M16x40_v9.50	2

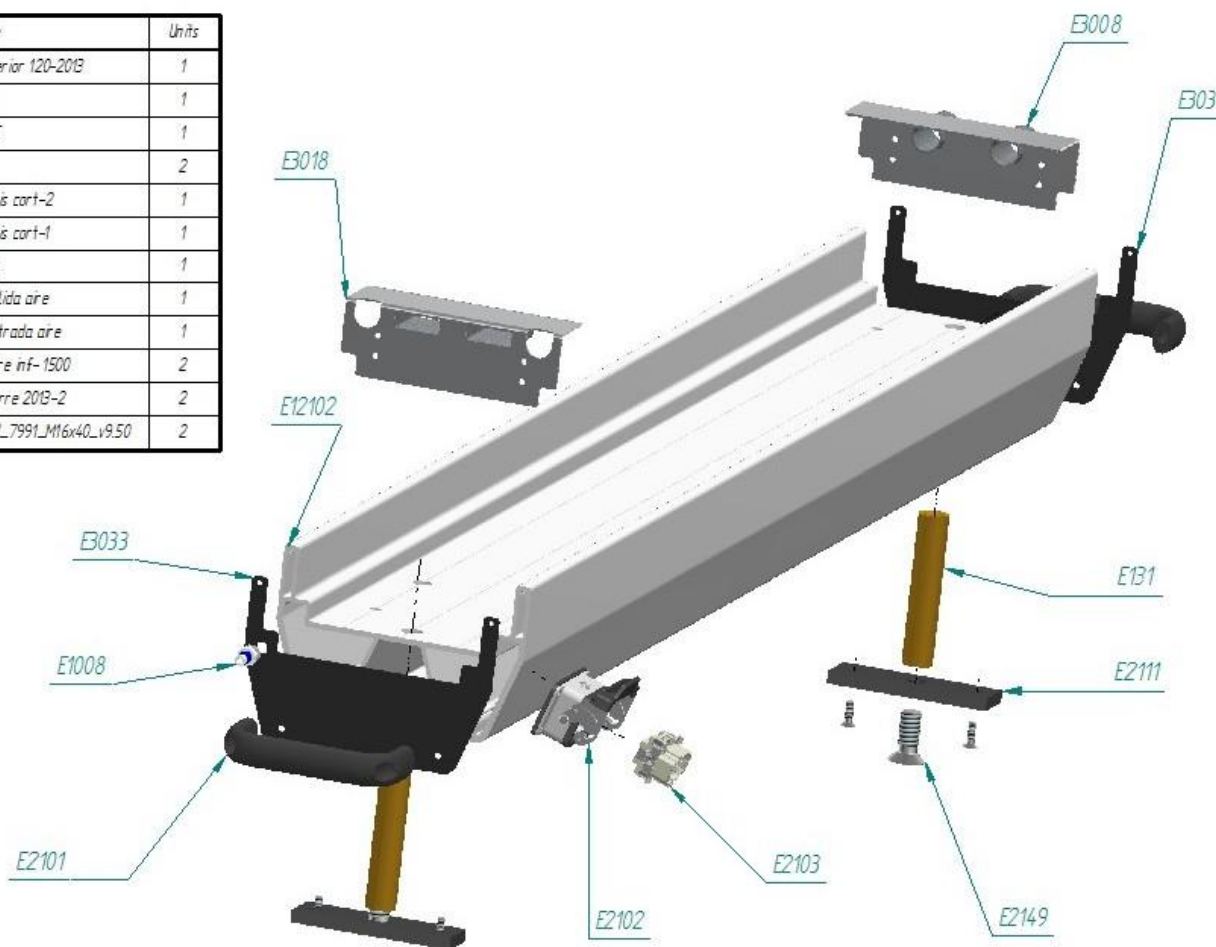

Número de documento	Part Name	Units
E12003	Cajín 1200 inferior	1
E12002	Cajín superior 1200r	1
EL1231	PLETINA CQ/W S	2
EL1232	PLETINA CQ/W I	2
EL1230	3009_08_11	1

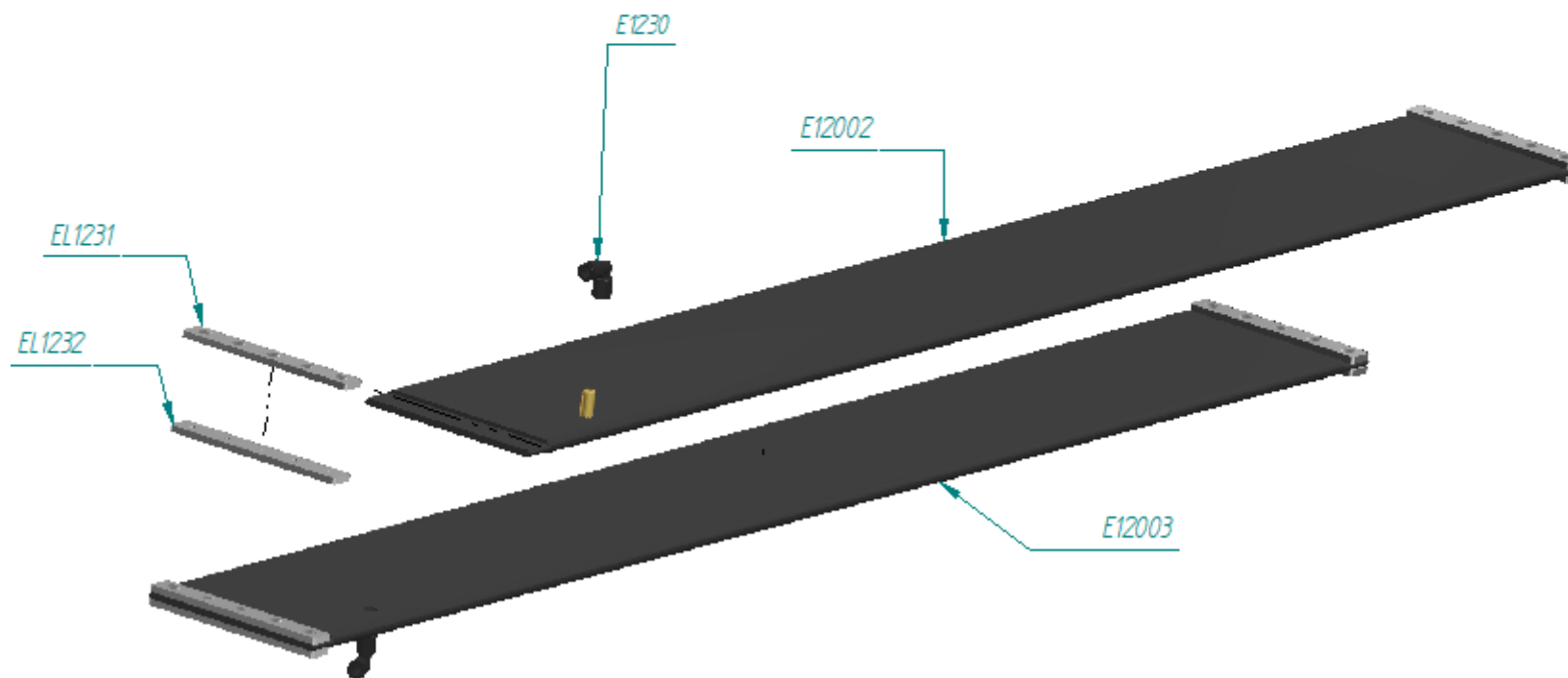

Number	Part name	Units
E4001	Bolt 912 M8 45par	4
E2104	Bolt 934_M8_v9.00,par	2
E4003	Bolt Din_444_m8_75_ni,par	4
E12024	Bottom silicone 120,par	1
E12023	Bottom tub 50x25x15	2
E4002	Distancial bolt top clamp	8
E12021	Fibre glass sheet	1
E4006	Handle top clamp	4
E4005	Nut_DN_982_M8_v9.50,par	4
E2113	Screw_DN_912_M8x65_v9.00,par	2
E12020	Steel plate 120	1
E12022	Top Clamp 120,par	2

